

# Palm Leaf Cross Directions

Supplies: One palm leaf strip about 24-26" in length, 1/2" in width, tapering to the end.

STEP: 1

Fold the palm leaf down,  
about 5-6" from the bottom.

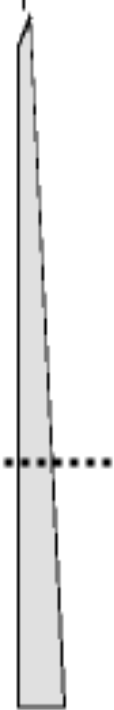

STEP: 2

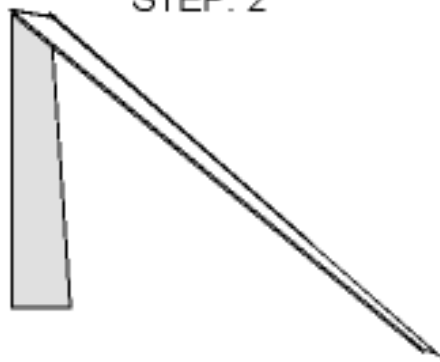

STEP: 3



STEP: 4

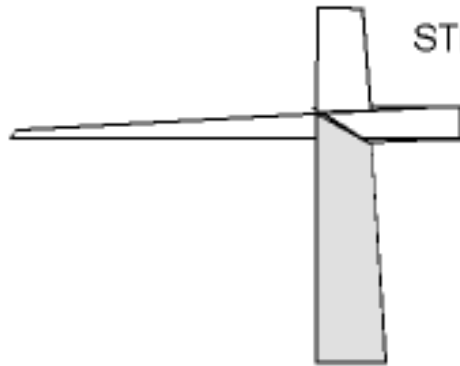

STEP: 5

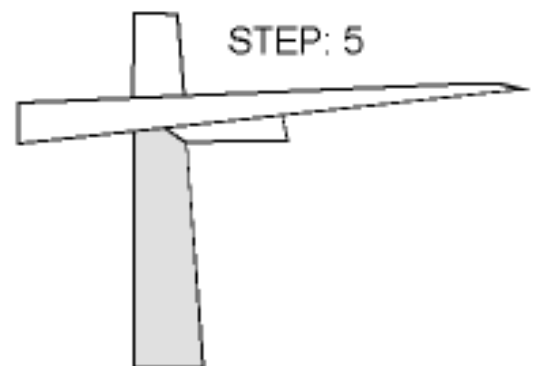

STEP: 6

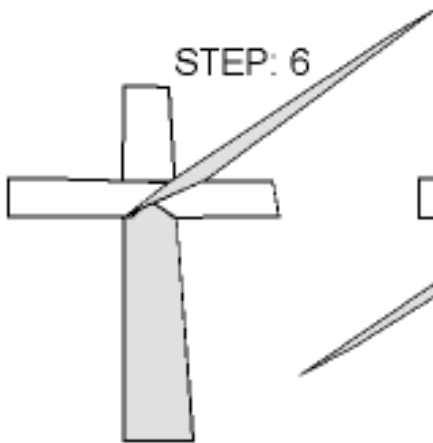

STEP: 7

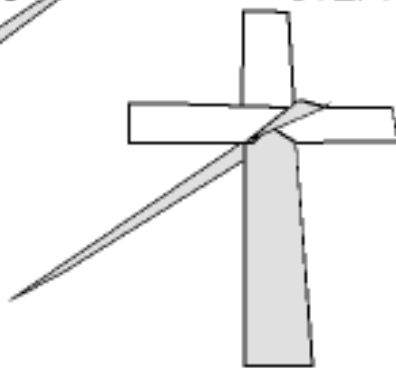

STEP: 8

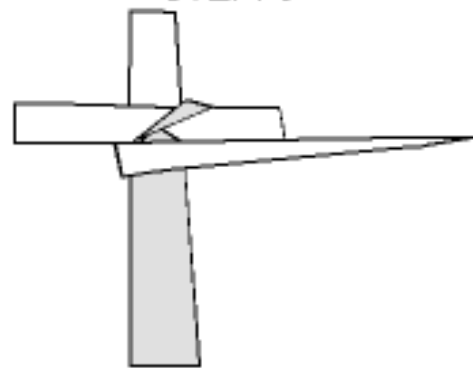

STEP: 9

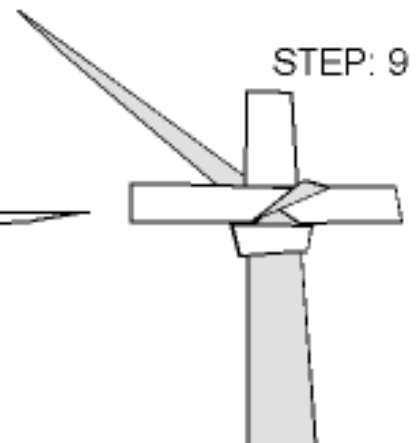

STEP: 10

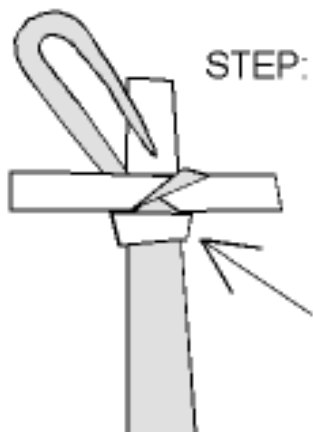

Tuck in the  
tapered end of  
the palm leaf  
and pull it  
through.

STEP: 11

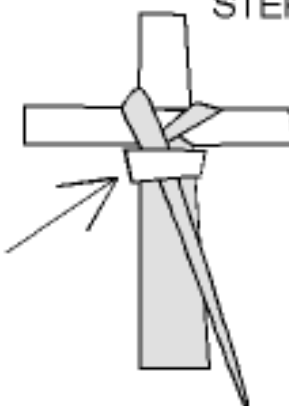

STEP: 12

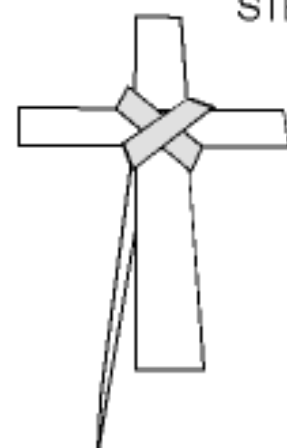

Turn the  
cross over.  
This is the  
front view.



Palm Sunday falls on the Sunday before Easter. It commemorates the triumphant entry of Jesus into Jerusalem, and it gets its name from the palm branches of the crowd scattered on the ground and waved as a sign of celebration, victory, and respect for Him as He rode in on a donkey.

HERE'S WHAT YOU'LL NEED TO GET STARTED:

**1. Ice Cream**

**2. Crushed Cookies**

The crushed cookies symbolize the rough and rocky road that Jesus traveled on when coming into Jerusalem.

**3. Green Candy for Palm Leaves**

You'll want to find a green candy for this one. You could use green sour straws, jelly beans, green sprinkles, fruit roll-ups, gummy worms, green raisins, etc. Alternately you can cut mint leaves to look like palm branches! You'll pour this on top of the crushed road to represent the palm branches that were waved and spread across the road during Jesus' arrival.

**4. Miniature Kit Kat**

This represents the donkey that Jesus rode on.

**5. Sour Patch Kid**

This represents Jesus. Gummy bears might also work.

**6. Sprinkles**

This represents the joy and celebration of the crowd as the Messiah entered Jerusalem.

**7. Reddi-Whip or Cool Whip**

This is solely just for aesthetics. You can't have ice cream without a little extra cream! Plus, it makes it so much easier to place Jesus, the donkey, and the sprinkles.

All of these ingredients together don't make the typical sundae, but children love to pile on the sweets when it comes to their ice cream, so I don't think the fact that there are contrasting flavors going on will be a problem. While creating your sundae, share the story and symbolism of this special day! Enjoy!